

12 Zasuwa nożowa - Knife gate valve - Robinet-vanne à montage entre brides

12.19 EB

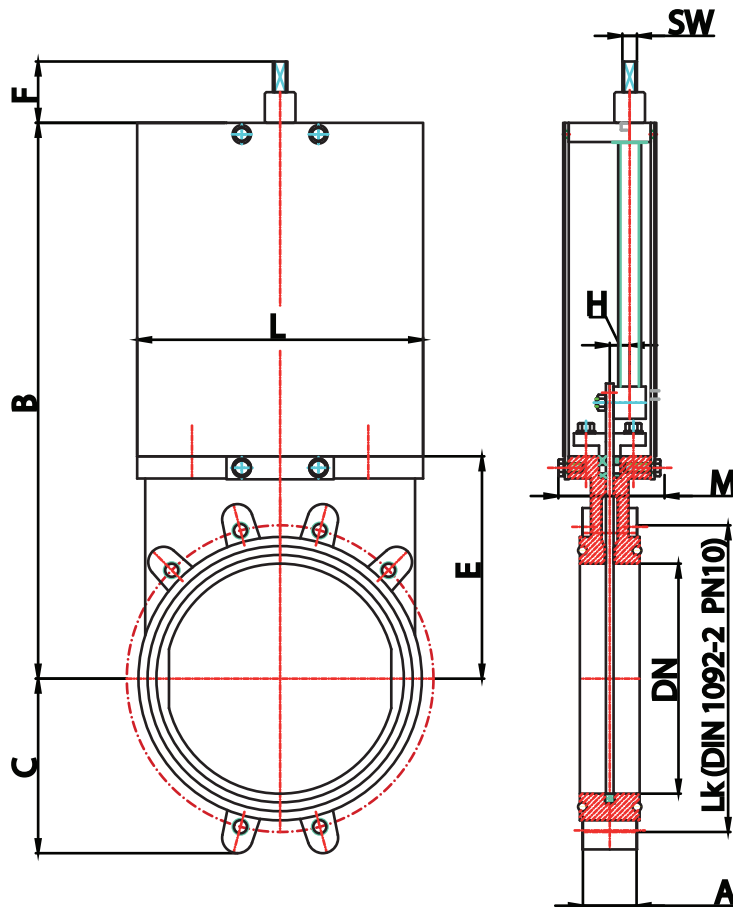

DN	A	B	C	D	E	G	H	SW
50	43	280	63	170	105	80	12	19
65	46	285	70	183	115	80	12	19
80	46	307	92	184	124	80	12	19
100	52	345	106	202	140	80	12	19
125	56	390	120	211	150	80	16,4	19
150	56	430	130	241	175	80	16,4	19
200	60	538	160	288	205	140	20	19
250	68	655	198	345	250		20	19
300	78	745	234	395	300	140	22	27
350	78	860	258	430	338	150	22	27
400	102	965	292	480	392	150	26	27
450	114				432	150	26	27
500	127	1185	340	592	485	150	38	27
600	110	1420	400	705	590	140	38	27
700	110	1675	452	787	760	140	30	27
800	110	1890	505	901	795	140	30	27
900	110	2115	555	1024	900	140	35	27
1000	110	2340	610	1108	980	140	35	27

12 Zasuwa nożowa - Knife gate valve - Robinet-vanne à montage entre brides

Werkstoffe Material Matériau

Korpus <i>Body Corps</i>	GG 25 (EN JL 1040)	GGG 40 (EN JS 1030)	1.4408 na zapytanie - on request - sur demande
Płyta <i>Plate Plaque</i>	1.4301	1.4571	
Trzpień <i>Spindle Tige</i>	1.4104	1.4305	1.4571
Zabezpieczenie powierzchni <i>Coating</i> <i>Traitement de couche</i>	EKB powłoka RAL 5015 ca. 200µ <i>EKB coated RAL 5015 ca. 200µ</i> <i>revetue de EKB RAL 5015 ca. 200µ</i>		
Uszczelka <i>Seal</i> <i>Composé</i>	EPDM/APTK; na zapytanie: Viton, Teflon <i>EPDM/APTK; on request: Viton, Teflon</i> <i>EPDM/APTK; sur demande: Viton, Teflon</i>		

Połączenie kołnierzowe dla BAP - Zasuwa nożowych wg EN 1092-2, owiert wg PN 10

Flange connection for BAP - knife gate valves according to EN 1092-2, drilled PN 10

Raccord à bride por robinet-vanne à montage entre brides EN 1092-2, percé selon PN 10

DN 50 - 65

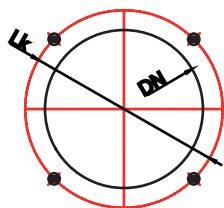

DN 80 - 200

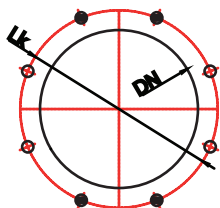

DN 250 - 300

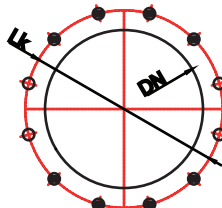

DN 350 - 400

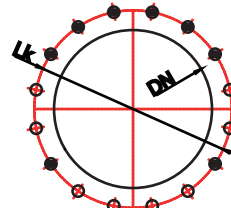

DN 450 - 600

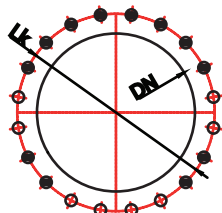

DN 700 - 800

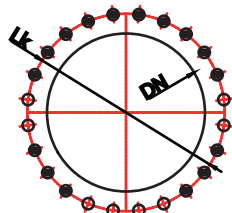

DN 900 - 1000

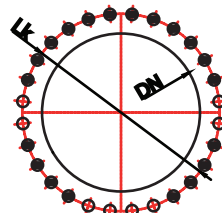

DN 1200

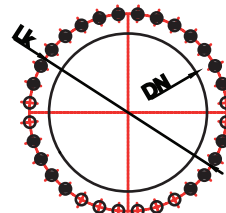

Średnica podziałowa kołnierzy wg EN 1092-2, owiercone wg PN 10

Bolt circle for flange according to EN 1092-2, drilled PN 10

Cercle des trous de boulons à montage entre brides EN 1092-2, percé selon PN 10

DN	50	65	80	100	125	150	200	250	300	350	400	450	500	600	700	800	900	1000	1200
k	125	145	160	180	210	240	295	350	400	460	515	565	620	725	840	950	1050	1160	1380
N	4	4	8	8	8	8	8	12	12	16	16	20	20	20	24	24	28	28	32
Nr	4	4	4	4	4	4	4	8	8	8	8	12	12	12	16	16	20	20	22
Np			4	4	4	4	4	4	4	4	4	4	4	8	8	8	8	8	10
Ng										4	4	4	4						
M	16	16	16	16	16	20	20	20	20	20	24	24	24	27	27	30	30	33	36
t	10	10	12	12	14	14	14	18	21	21	28	30	40	26	20	20	20	20	35

N = Całkowita liczba otworów - Total number of holes - Total de trous

NR = Liczba otworów z gwintem, nieprzelotowych - Number of blind holes with thread - Nombre de a trous à sacs avec filet

Np = Liczba otworów przelotowych - Nuber of through holes - Nomber des trous par marchant

t = Głębokość otworów z gwintem, nieprzelotowych - Blind holes depth - Profondeur des trous à sacs